

EcoCduty – for Superior Cost Efficiency

Large-Chamber Cleaning System



ECOCLEAN

technology that inspires



➤ Cleaning heavy and large-sized parts in a cost-efficient manner – across all industries.

For cost-efficient degreasing and part cleaning, machines capable of handling very high capacities in a reliable, economical and energy-saving manner at high speeds are required, in particular, in hardening and metalforming applications as well as in the automotive and aircraft industries.

The innovative EcoCduty large-chamber cleaning system relies on hydrocarbons or polar solvents (modified alcohols) and is rated for loads measuring 1,250 x 840 x 970 mm and weighing up to 1 tonne. Thanks to its modular design, this large-chamber full-vacuum cleaning unit can be adapted flexibly to specific user requirements. Configured as a steam degreaser in its standard version, it is additionally available

with one or two flood tanks (e.g., for a process comprising steam degreasing and injection flood washing or steam degreasing, injection flood washing plus a preserving step). The system can effectively remove chlorinated metal-working fluids. Moreover, it is fully suitable for cleaning off sulphur-containing oils.

Technical data			
EQUIPMENT DIMENSIONS			
	Steam degreaser	1-tank	2-tank
Width	5,200 mm	6,700 mm	8,500 mm
Depth	3,000 mm	3,000 mm	3,000 mm
Height	3,500 mm	3,500 mm	3,500 mm
BASKET DATA			
L x W x H	1,250 x 840 x 970 mm		
LOADS			
Load weight (max.)	1,000 kg		
Throughput	approx. 5-6 loads/h	approx. 3-4 loads/h	approx. 2-3 loads/h
POWER RATINGS			
System	approx. 25 kW	approx. 32 kW	approx. 40 kW
Heating power	approx. 60 kW (steam, gas, oil or electrical)		
OPERATING TEMPERATURE			
Depending on solvent	45-120 °C		

Your Benefits

+ FLEXIBILITY TO MATCH APPLICATION NEEDS

- Versatile full-vacuum cleaning operation using hydrocarbons or modified alcohols
- Modular design: available as a steam degreaser with vacuum drier or additionally with one or two flood tanks
- Loading solutions "as needed" to meet individual requirements

+ HIGH COST EFFICIENCY

- High capacity and performance: product loads weighing up to 1 tonne are handled in short cycle times (up to 6 loads/hour)
- Long service life: a high-performance filter unit reliably removes contaminant particles from the solvent
- Accelerated cleaning process: powerful frequency-controlled pumps minimize non-productive times
- Energy-efficient heating of flood tanks due to heat recovery
- Low investment and operating costs, plus short lead times

+ RELIABLE CLEANING QUALITY

- Improved degreasing performance: oil accumulation in the flood tank is minimized by an innovative steam pre-degreasing system
- Full-flow filtration ensures dependable compliance with high cleanliness standards
- Horizontally arranged cylindrical flood tanks prevent the formation of dirt pockets more effectively than rectangular tanks

+ SAFE OPERATION

- Environmentally sound, almost emission-free equipment technology
- Easy and safe to operate: 7" colour display using self-explanatory pictographs
- Ease of maintenance: large maintenance hatches provide quick access to service-related components

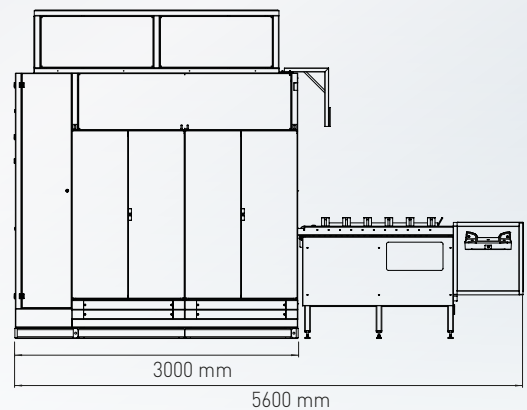
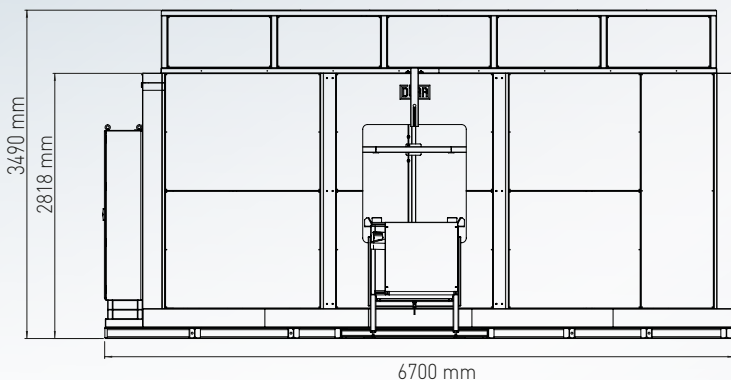

➤ Dimensions stated for a single-tank version

Our Locations Worldwide

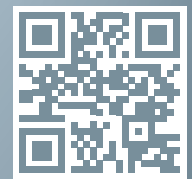
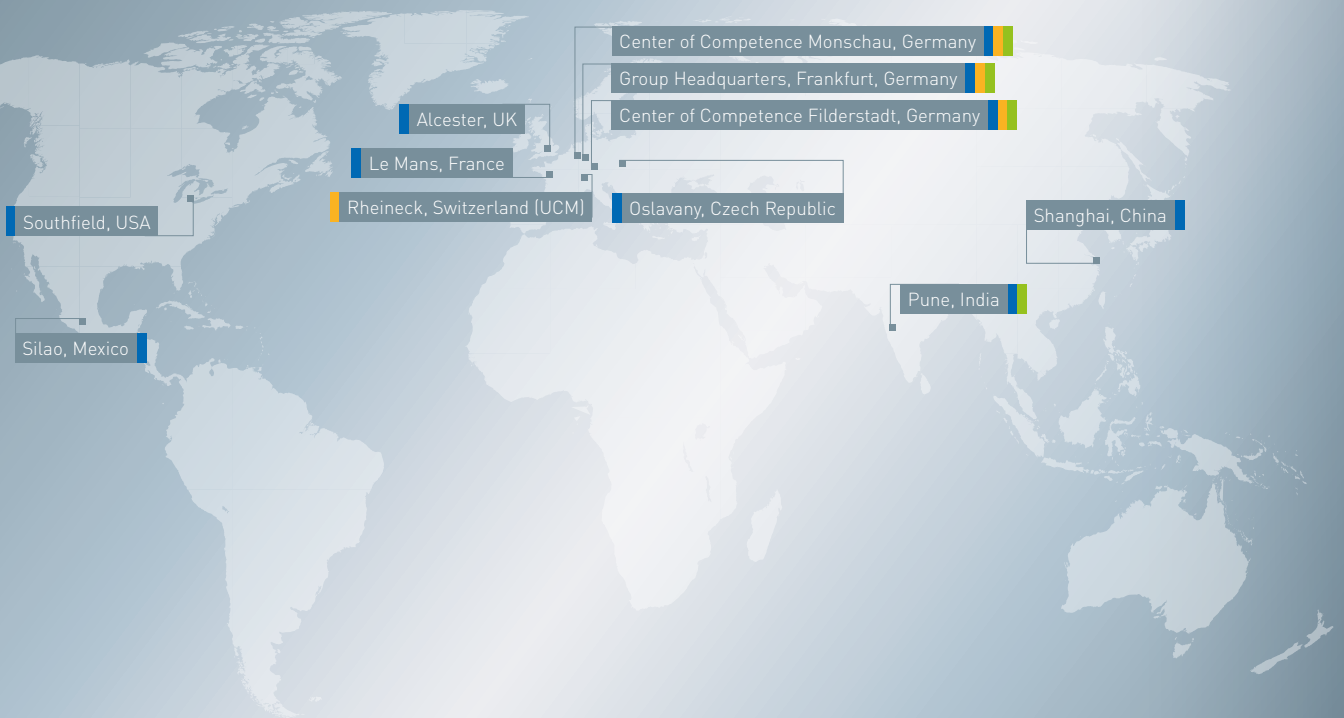

SBS ECOCLEAN GROUP